



Ø35

ART.

KR36AS

CARTUCCIA Ø35
CARTRIDGE Ø35

MATERIALE DISCHI - DISC MATERIAL (Al_2O_3)
TEST DURATA - LONG TERM TESTS
UNI EN 817 (70.000 CICLI - LIFECYCLE)
ASME (500.000 CICLI - LIFECYCLE)
COPPIA SERRAGGIO - TORQUE (10Nm)
PRESSIONE MAX PRESSURE AIR (10BAR)
PRESSIONE MAX PRESSURE WATER (50BAR)
ROTAZIONE LEVA - LEVER ROTATION (100°)
PORTATA - FLOWRATE (30 l/min - 3 BAR)

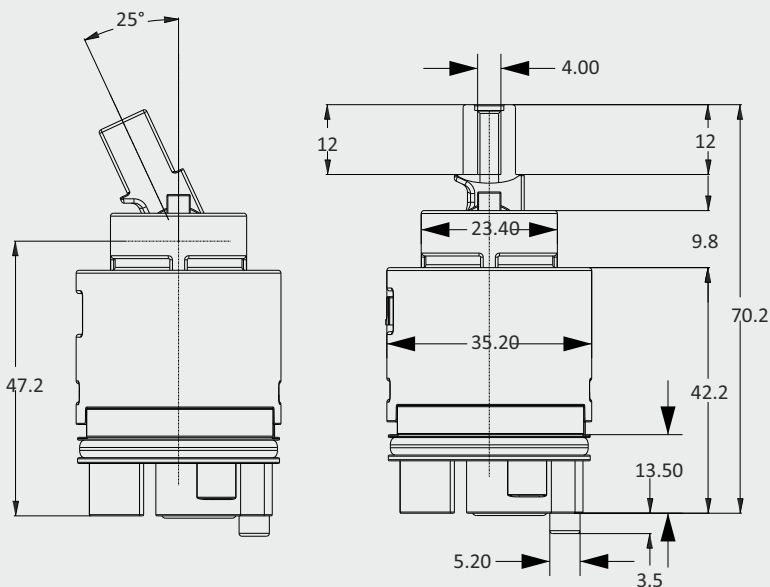
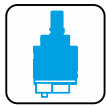



KERANICAL SRL



C US
LLC-LowLead
Content
(NSF-ANS161)

Ø35

ART.
KR36AS
CARTUCCIA Ø35
CARTRIDGE Ø35

