



# Ø35

ART.

## KR35B

**CARTUCCIA Ø35 STANDARD  
CARTRIDGE Ø35 STANDARD**

MATERIALE DISCHI - DISC MATERIAL ( $Al_2O_3$ )  
 TEST DURATA - LONG TERM TESTS  
 UNI EN 817 (70.000 CICLI - LIFECYCLE)  
 ASME (500.000 CICLI - LIFECYCLE)  
 COPPIA SERRAGGIO - TORQUE (10Nm)  
 PRESSIONE MAX PRESSURE AIR (10BAR)  
 PRESSIONE MAX PRESSURE WATER (50BAR)  
 ROTAZIONE LEVA - LEVER ROTATION (100°)  
 PORTATA - FLOW RATE (30 l/min - 3 BAR)  
 DISPOSITIVO LIMITAZIONE TEMPERATURA  
 HOT WATER LIMITER

9x9

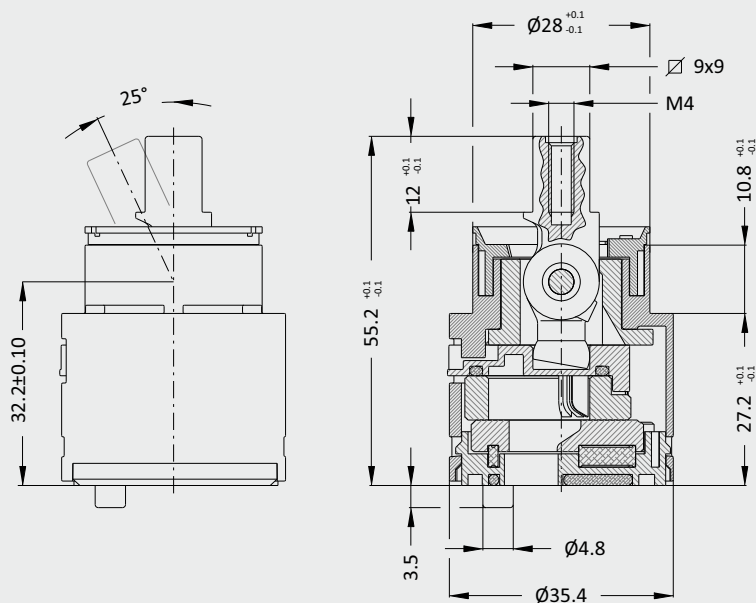



**KERANICAL** SRL



ISO 9001  
BUREAU VERITAS  
Certification



US  
LLC-LowLead  
Content  
(NSF-ANSI61)



Water Regulations Advisory Service



Technologiezentrum  
Wasser  
on ref. at  
DVGW

# Ø35

ART.  
**KR35B**  
CARTUCCIA Ø35  
CARTRIDGE Ø35

Coppia di serraggio  
tightening torque 8/12 Nm

