



Ø40

ART.

KR40ASK

CARTUCCIA Ø40 ECOBLOCK STEP
CARTRIDGE Ø40 ECOBLOCK STEP

MATERIALE DISCHI - DISC MATERIAL (Al_2O_3)
TEST DURATA - LONG TERM TESTS
UNI EN 817 (70.000 CICLI - LIFECYCLE)
ASME (500.000 CICLI - LIFECYCLE)
COPPIA SERRAGGIO - TORQUE (10Nm)
PRESSIONE MAX PRESSURE AIR (10BAR)
PRESSIONE MAX PRESSURE WATER (50BAR)
ROTAZIONE LEVA - LEVER ROTATION (110°)
PORTATA - FLOW RATE (36 l/min - 3 BAR)
ECOBLOCK STEP (12/36l/min)

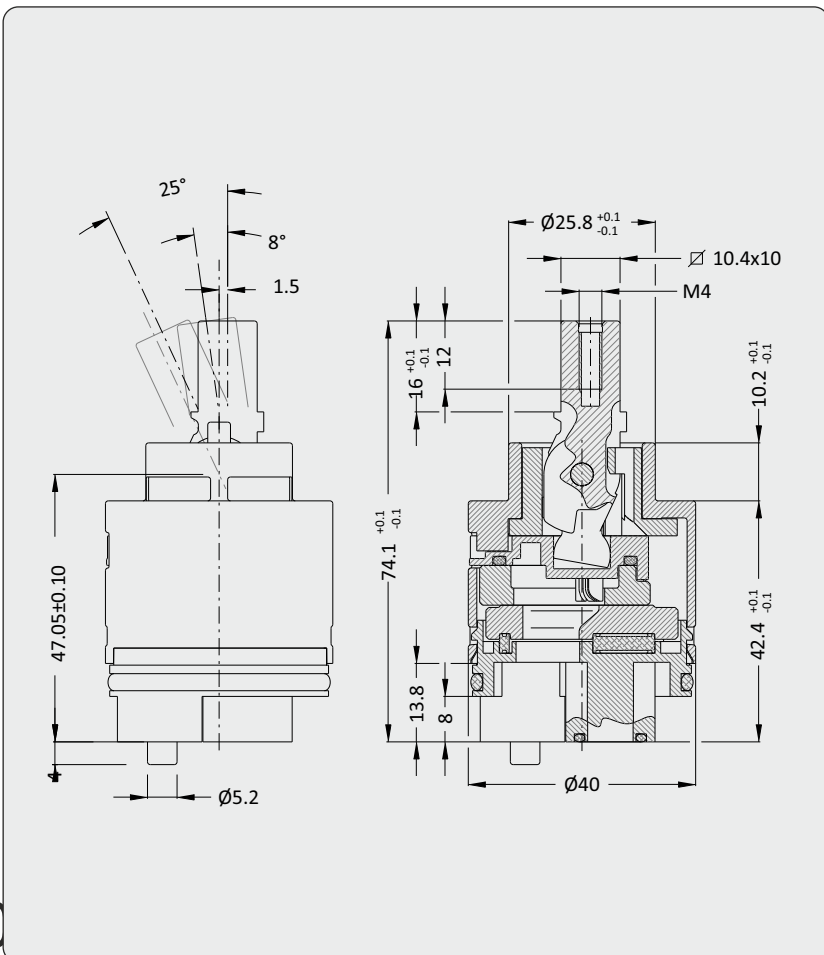



KERANICAL SRL



ISO 9001
BUREAU VERITAS
Certification



C US
LLC-LowLead
Content
(NSF-ANSI61)



Water Regulations Advisory Service



Technologiezentrum
Wasser
on ref. at
DVGW

Ø40

ART.
KR40ASK
CARTUCCIA Ø40
CARTRIDGE Ø40

Coppia di serraggio
Tightening Torque 8/12 Nm

