



# Ø40

ART.

## KR40ASKR

**CARTUCCIA Ø45 ECOBLOCK STEP  
CARTRIDGE Ø45 ECOBLOCK STEP**

MATERIALE DISCHI - DISC MATERIAL ( $Al_2O_3$ )  
 TEST DURATA - LONG TERM TESTS  
 UNI EN 817 (70.000 CICLI - LIFECYCLE)  
 ASME (500.000 CICLI - LIFECYCLE)  
 COPPIA SERRAGGIO - TORQUE (10Nm)  
 PRESSIONE MAX PRESSURE AIR (10BAR)  
 PRESSIONE MAX PRESSURE WATER (50BAR)  
 ROTAZIONE LEVA - LEVER ROTATION (110°)  
 PORTATA - FLOW RATE (36 l/min - 3 BAR)  
 ECOBLOCK STEP (12/36/min)  
 FONDO RUOTATO (SX)- ROTATED GROUND (L)

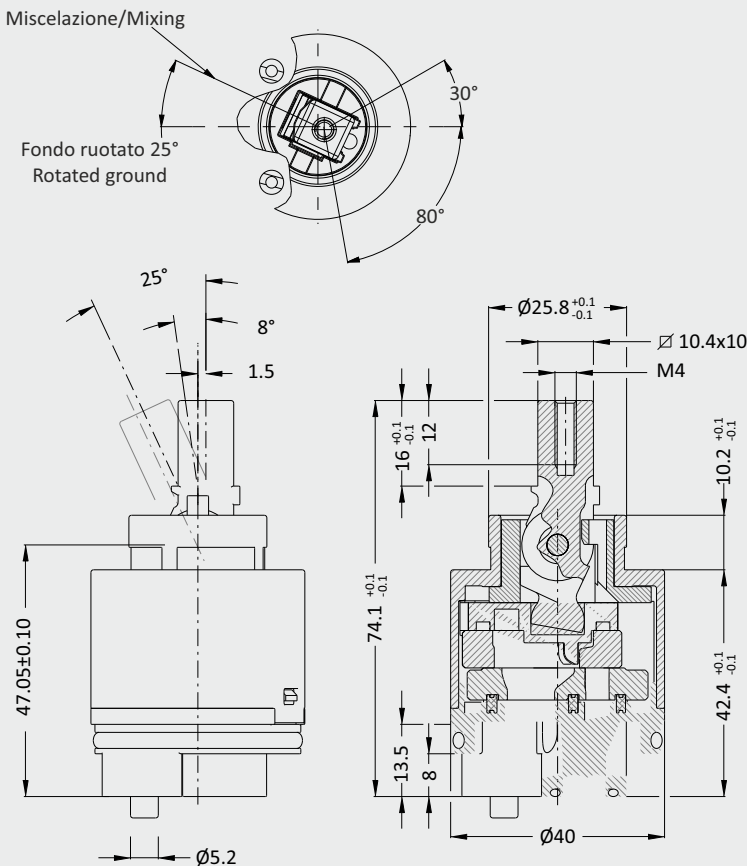
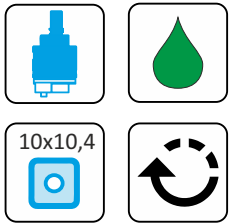



**KERANICAL** SRL



ISO 9001  
BUREAU VERITAS  
Certification



US  
LLC - Low Lead  
Content  
(NSF-ANSI61)



Water Regulations Advisory Service



Technologiezentrum  
Wasser  
on ref. at  
DVGW

**Ø40**

ART.  
**KR40ASKR**  
CARTUCCIA Ø45  
CARTRIDGE Ø45

Coppia di serraggio  
Tightening Torque 8/12 Nm

